



R4-EM-05 Series Electromechanical Rotary Latch

Compact Size · Door Sense Option

Electronic access with internal motor control

- Push-to-close, electronic release
- Compact design
- Sensors ensure secure latch & door
- Latch releases reliably even under high load
- Integrated mechanical over-ride

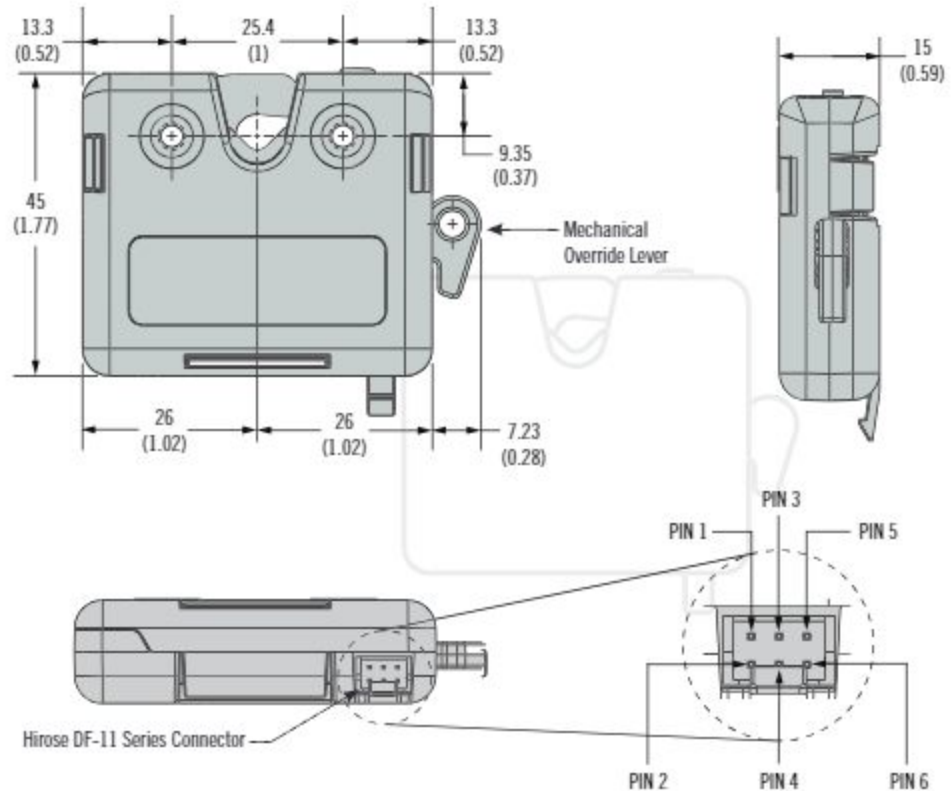

Part Number Selection

R4 - EM - **T** **M** 0 - 1 **S** 0 - **P**

T Operation Style

- 05A Auto relock
- 05D Delayed relock
- See page 21 for operation details

M Mounting Type

- 0 4.5mm thru
- 1 8-32 UNC
- 2 M4x0.7

- P** Packaging Options
- None Individually packaged
 - 1 Bulk packaged

S Sensor Options

- 0 - Latch Sensor Only
 - 5 - Latch & Door Sensor*
- * Door sensor requires door sensor bracket

Installation

Panel Preparation

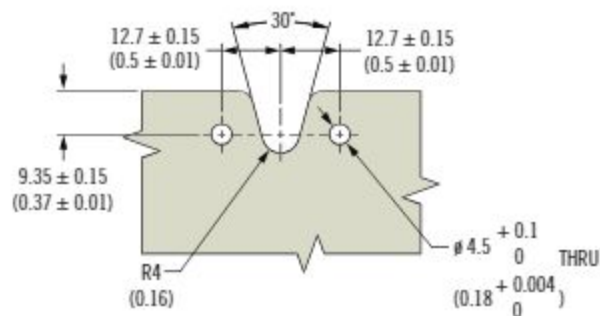

Dimensions in millimeters (inch) unless otherwise stated

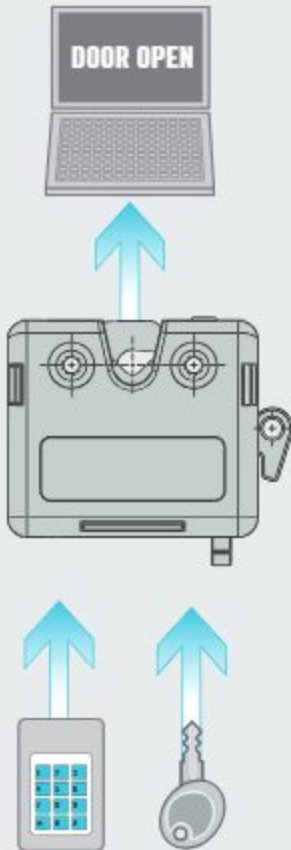

Optional Striker and Door Sensor Bracket

Part Number	
Molded Striker	R4-0-61336
Door Sensor Bracket	R4-99-966

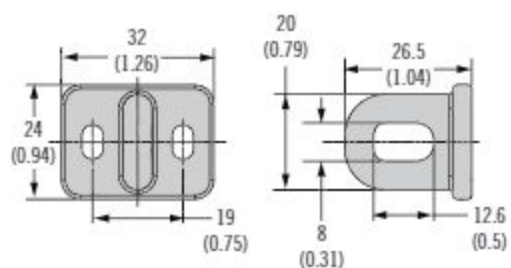

Part Number	
Wire Form Striker	R4-0-71060
Door Sensor Bracket	R4-99-966-1

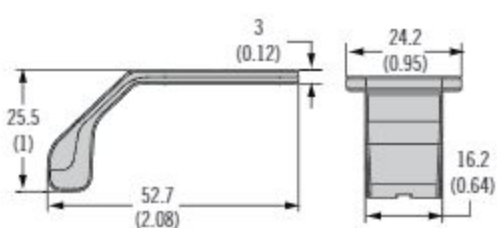
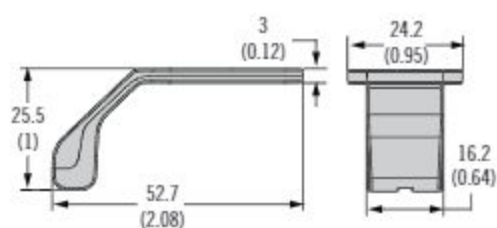
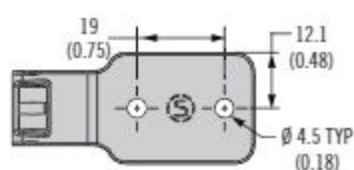
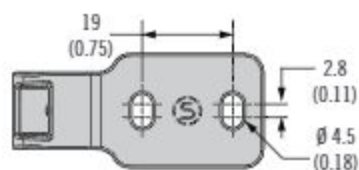
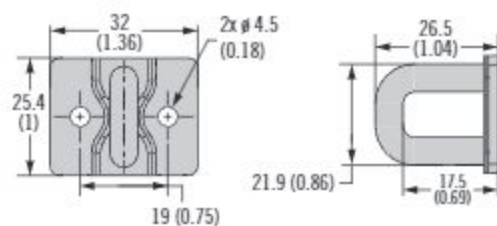

Material and Finish

Housing: PC/ABS

Latch frames, Pivot pins, Cam and

Trigger: Steel, zinc plated

Striker: Steel, zinc plated
or Glass-filled nylon, black

Door Sensor Bracket: PC/ABS, Magnet:
Neodymium

Recommended Operating Voltage:
5 to 12 VDC

Typical Operating Current:
Less than 500mA

Latch Connector

PIN Assignment

PIN 1: Ground (-)

PIN 2: Power (+)

PIN 3: Not connected

PIN 4: Control signal

PIN 5: Latch status

PIN 6: Door status

Door Sensor Bracket *

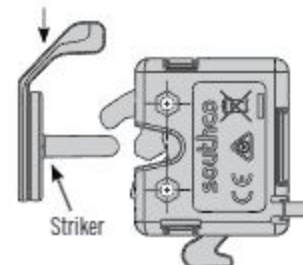

* Door sensor bracket required for
door sense capability

Electronic Actuators

See page 48



Mechanical Actuators

See page 34



Cables

See page 322



Wiring/Junctions

See www.southco.com



REVISION HISTORY			
REV	DATE	BY	DESCRIPTION
C	25OCT2022	IGS/NPS	PRN: P2022-1127

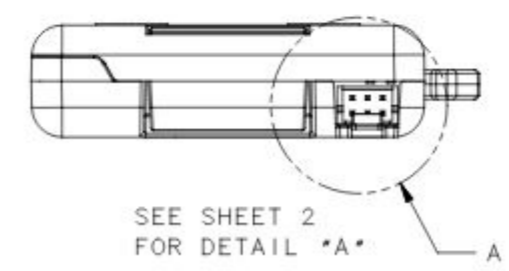
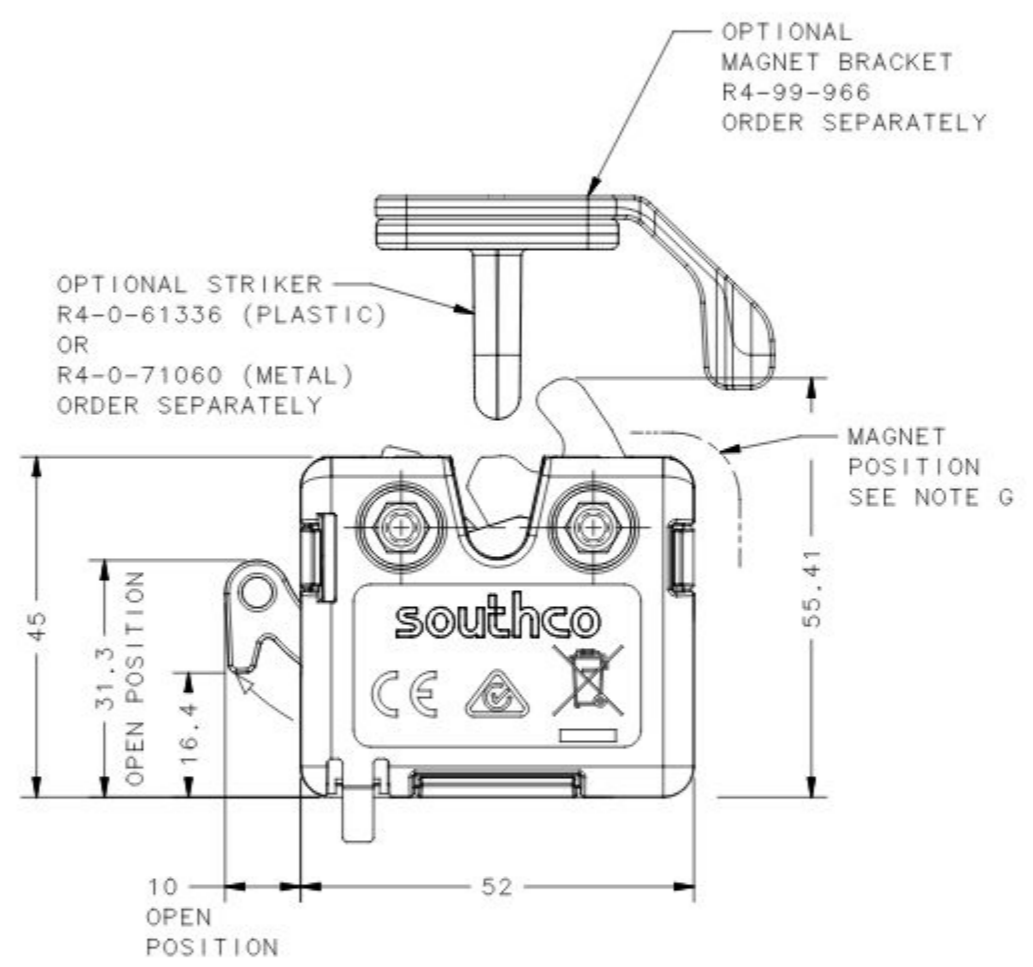
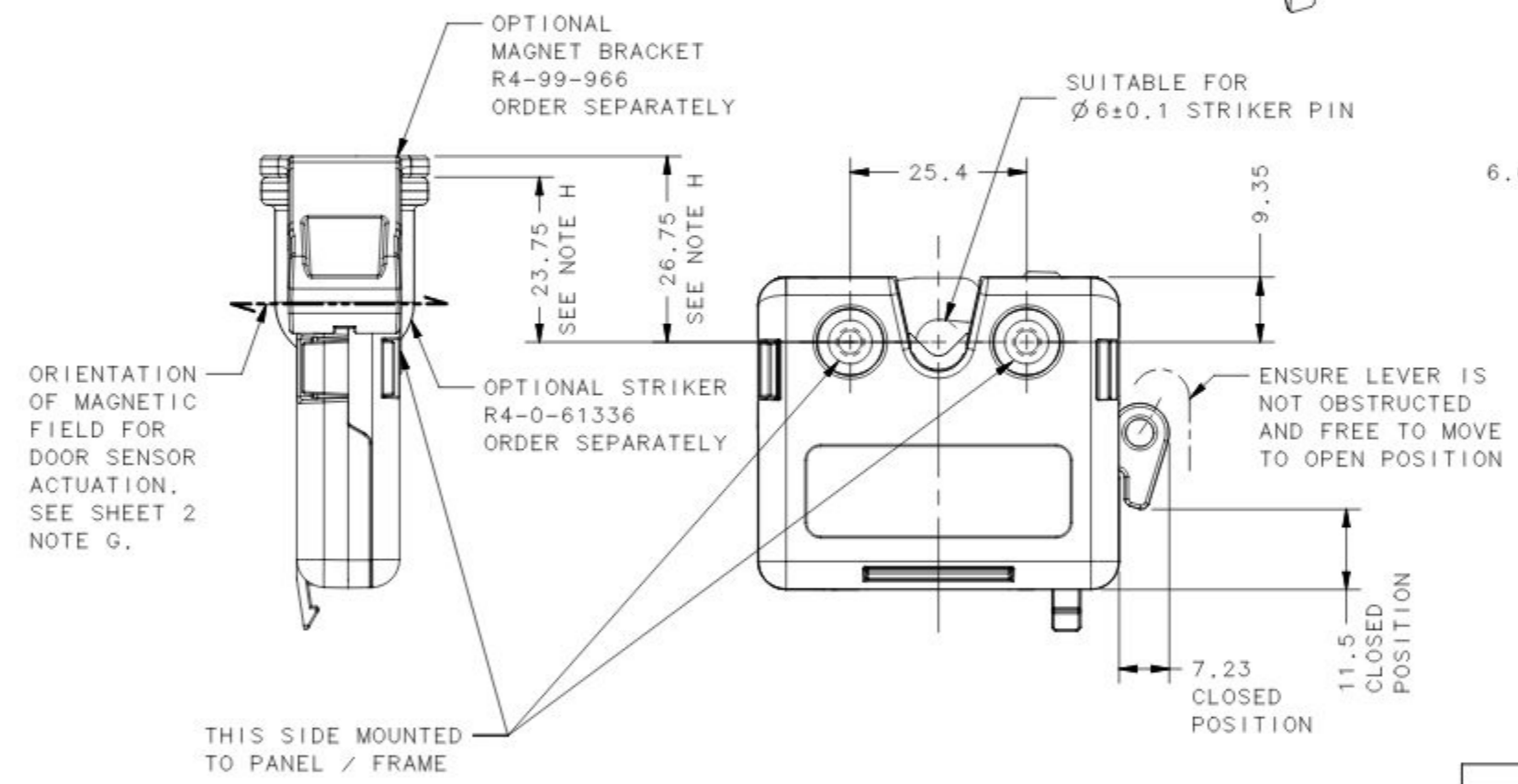
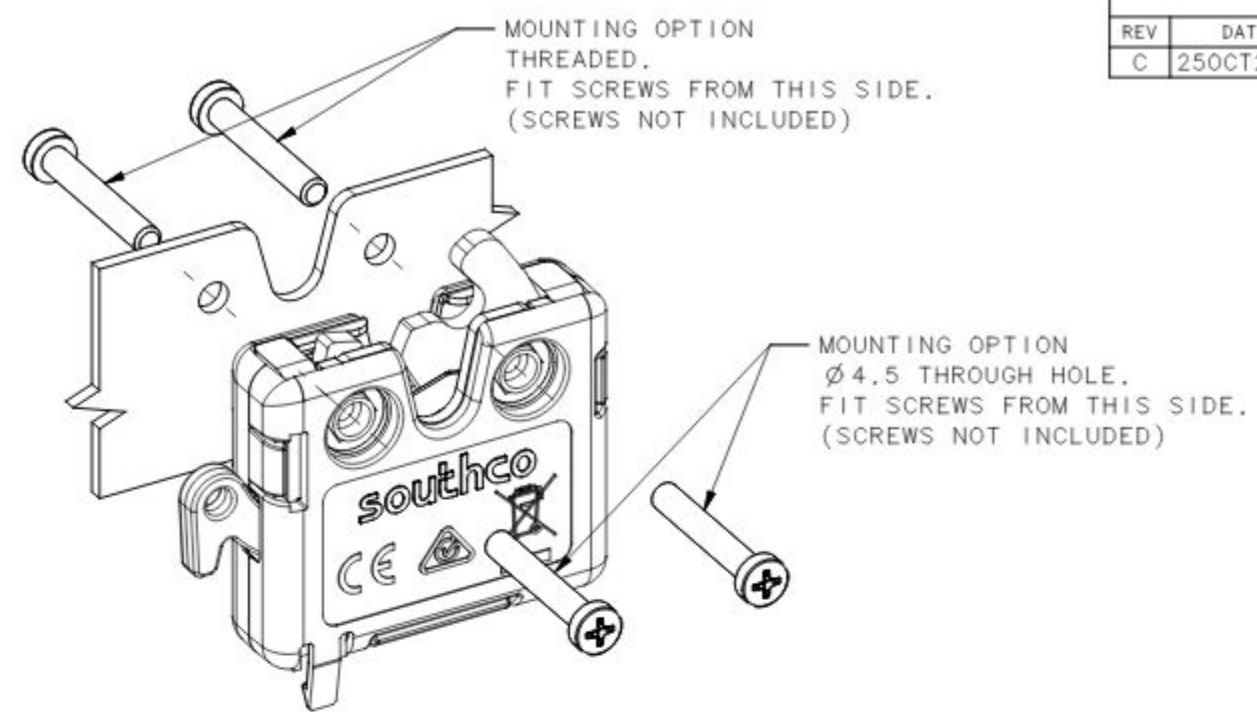
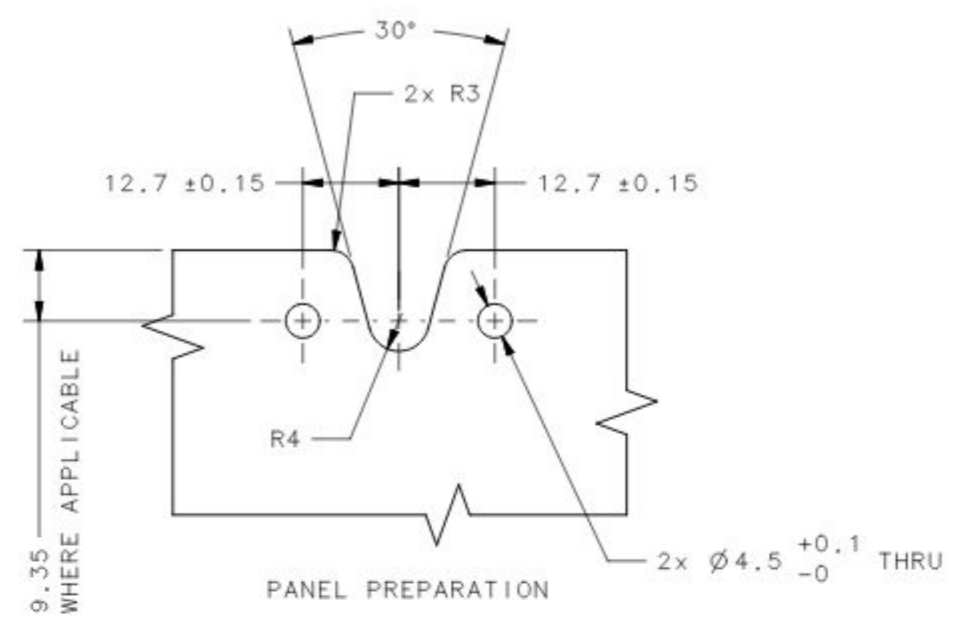

PRINTED CIRCUIT BOARD	PCB	N/A	-
DRIVE CAM / OUTPUT CAM	POM	N/A	-
SPRINGS	STAINLESS STEEL	PASSIVATED	-
ROTARY PAWL / TRIGGER	STEEL	ZINC PLATED	-
LATCH FRAMES	STEEL	ZINC PLATED	-
HOUSINGS	PC/ABS	N/A	-
SEE SHEET 2 PART NUMBER	ELECTRONIC ACCESS SOLUTION	N/A	N/A
	TYPE OF COMPONENT	MATERIAL	FINISH
			LATCH ASSEMBLY NOTES

THIRD ANGLE PROJECTION				southco [®] CONNECT • CREATE • INNOVATE	
MILLIMETERS [IN]					
SURFACE AREA		TOLERANCES UNLESS OTHERWISE NOTED		DESCRIPTION	
VOLUME		ALL DIMENSIONS WITHOUT TOLERANCES ARE FOR REFERENCE ONLY.		ELECTRONIC ACCESS SOLUTION MINIATURE ROTARY LATCH	
PROPRIETARY ITEM		SIZE	SYSTEM	DWG NO.	
EXCEPT FOR USES EXPRESSLY GRANTED IN WRITING, INFORMATION DISCLOSED HEREON IS CONFIDENTIAL AND ALL RIGHTS, PATENT AND OTHERWISE, ARE RESERVED BY SOUTHCO, INC.		A3	NX	J-R4-EM-05-1	
PER ASME Y14.5M-1994		DRAWN BY	DATE	SCALE	SHEET
		IGS/NPS	03JUL2019	1:1	1 OF 2

REVISION HISTORY			
REV	DATE	BY	DESCRIPTION
C	25OCT2022	IGS/NPS	PRN: P2022-1127

NOTES:

- A. MOUNTING**
 -MOUNT THE LATCH WITH THE CORRECT SIDE AGAINST THE ENCLOSURE FRAME/PANEL AS SHOWN ON SHEET 1 USING TWO SCREWS IN THE MOUNTING HOLES PROVIDED (SCREWS NOT PROVIDED).
 -MAXIMUM ALLOWABLE TORQUE ON MOUNTING SCREWS IS 4Nm.
- B. ELECTRICAL SPECIFICATIONS:**
 OPERATING VOLTAGE: 4.5 TO 16 VDC
 TYPICAL OPERATING CURRENT: LESS THEN 500 mA
 PEAK / STALL OPERATING CURRENT: 0.5 A MAX AT 4.5 VDC, 1.0 A MAX AT 12.0 VDC, 1.5 A MAX AT 16.0 VDC (STALL LIMITED BY LATCH TO 1.4 SECONDS)
 TOTAL STANDBY CURRENT: LOCKED/UNLOCKED: 20mA EXCLUDING STATUS OUTPUT CURRENTS.
 CONTROL SIGNAL HIGH (UNLOCK COMMAND): 0.2mA STEADYSTATE TO 1.2mA INRUSH WITH $V_{in} AT = VDC$.
 CONTROL SIGNAL LOW (LATCHED COMMAND): 0 TO 1 VDC.
 LATCH TRANSIT TIME TO RELEASE: APPROXIMATELY 600 MILLISECONDS NO LOAD, AT ROOM TEMPERATURE. MOTOR ACTIVATION TIME LIMITED TO 1.4 SECONDS (STALL DETECTION).
 OPERATING TEMPERATURE RANGE: 0°C TO +60°C
- C. ELECTRICAL CONNECTIONS AND HOOKUP:**
 A BASIC SWITCH CONTROL ELECTRICAL HOOKUP DIAGRAM IS PROVIDED FOR REFERENCE. CONSULT WITH A SOUTHCO REPRESENTATIVE FOR ADDITIONAL ELECTRICAL HOOKUP INFORMATION.
 - CONNECT POWER, GROUND AND CONTROL SIGNAL WIRES TO AN APPROPRIATE DC POWER SUPPLY
 - A DC POWER SUPPLY CAPABLE OF SUPPLYING 4.5 TO 16 VDC AT 1 AMP MINIMUM PER LATCH IS RECOMMENDED
 - POWER MUST BE AVAILABLE TO OPERATE THE LATCH AND MUST REMAIN AVAILABLE DURING THE FULL TRANSIT TIME OF THE LATCH DURING LOCKING OR UNLOCKING
- CAUTION!** LATCH CAN BE DAMAGED IF WIRED INCORRECTLY, OR IF IMPROPER VOLTAGE IS APPLIED!
 CONNECTOR PIN ASSIGNMENT: SEE CONNECTOR PINOUT TABLE AND PIN LOCATION DETAILS
- OUTPUT FEEDBACK (LATCH AND DOOR STATUS):
 STATUS INDICATION: OPEN DRAIN OUTPUT, RATING 4.5 TO 16 VDC, 50 mA MAX LOAD
CAUTION! TO PREVENT DAMAGE TO THE PRODUCT DO NOT EXCEED MAXIMUM LOADS STATED AND FOLLOW WIRING DIRECTIVES.
- D. ELECTRICAL OPERATION:**
 TO UNLOCK OR RELEASE THE LATCH:
 PROVIDE THE FOLLOWING CONTROL SIGNAL TO CONNECTOR PIN 4
 - PROVIDE 4.5 TO 16 VDC (CONTROL SIGNAL HIGH) FOR A MINIMUM OF 50 MILLISECONDS
 - THE CONTROL SIGNAL CAN REMAIN HIGH INDEFINITELY
 - DELAYED RE-LOCK LATCH: THE LATCH WILL STAY UNLOCKED FOR A MINIMUM OF 1 MILLISECOND OR AS LONG AS THE CONTROL SIGNAL REMAINS HIGH.
 - AUTO RE-LOCK LATCH: THE LATCH WILL UNLOCK AND RE-LOCK IF THE SIGNAL REMAINS HIGH.
 TO LOCK THE LATCH FOR A NEW OPENING CYCLE:
 PROVIDE THE FOLLOWING CONTROL SIGNAL TO CONNECTOR PIN 4
 - PROVIDE CONTROL SIGNAL LOW FOR 50 MILLISECONDS. POWER MUST BE AVAILABLE DURING TRANSIT TO THE LOCKED POSITION. TRANSITION TIME TO RE-LOCK APPROXIMATELY 200 MILLISECONDS
- E. WIRELESS OPERATION:**
 CONTACT SOUTHCO FOR INFORMATION.
- F. LATCH CONNECTOR:**
 MANUFACTURER: HIROSE ELECTRIC CO LTD, PART NUMBER: DF11-6DP-2DSA OR APPROVED EQUIVALENT.
 MATING CONNECTOR: (NOT SUPPLIED)
 -CONNECTOR: RECEPTACLE HOUSING, DUAL ROW, 6 POSITION: HIROSE: P/N DF11-6DS-2C OR APPROVED EQUIVALENT.
 -CONTACTS: FEMALE CRIMP TERMINAL (SOCKET) HIROSE P/N DF11-2428SC OR DF11-2428SCF OR APPROVED EQUIVALENT.
- WIRE HARNESS IS AVAILABLE, SOUTHCO P/N: EA-W01-X00 WHERE X-LENGTH IN METRES.
 X = 1 TO 5
 OTHER HARNESSES AVAILABLE, CONTACT SOUTHCO.
- G. FOR USING DOOR SENSOR CAPABILITY WITHOUT SOUTHCO MAGNET BRACKET IT IS NECESSARY TO POSITION A SUITABLE MAGNET ON THE DOOR TO APPROACH THE LOCATION SHOWN ON SHEET 1 WHEN THEN DOOR IS CLOSED. THE SWITCH POINT NEEDS TO BE ESTABLISHED BY TESTS IN THE APPLICATION DUE TO THE INFLUENCE OF NEARBY FERROUS METAL OBJECTS ON THE MAGNETIC FIELD.**
- H. DIMENSIONS FOR GUIDANCE ONLY. SUBJECT TO DOOR-LATCH ANGULAR ALIGNMENT. RELEVANT WHERE SOUTHCO KEEPER OR SOUTHCO MAGNET BRACKET AND KEEPER IS USED.**

ASSEMBLY PART NUMBER

R4-EM-TMA-VSC-P

***T* OPERATION STYLE**
 05A = AUTO RE-LOCK KICK-OUT
 05D = DELAYED RE-LOCK KICK-OUT

***M* MOUNTING TYPE**
 0 = 4.5mm THRU
 1 = 8-32 UNC
 2 = M4x0.7

***P* PACKAGING**
 BLANK = INDIVIDUAL
 1 = BULK/LAYER

***C* WIRELESS COMMUNICATION**
 0 = HARD WIRED ONLY
 1 = WIRELESS AND/OR HARD WIRED
 SEE NOTE E.

***S* SENSOR/OUTPUT OPTIONS**
 (ALL OPTIONS INCLUDE LOCKED SENSOR OUTPUT)
 0 = WITHOUT DOOR SENSOR
 1 = WITHOUT DOOR SENSOR, REVERSE OUTPUT
 5 = WITH DOOR SENSOR
 6 = WITH DOOR SENSOR, REVERSE OUTPUT

***V* VOLTAGE:**
 1 = 4.5 - 16 VDC

***A* ALTERNATIVE CONFIGURATIONS:**
 0 = STANDARD CONFIGURATION:
 MANUAL OVERRIDE, STD PAWL, STD SPRING

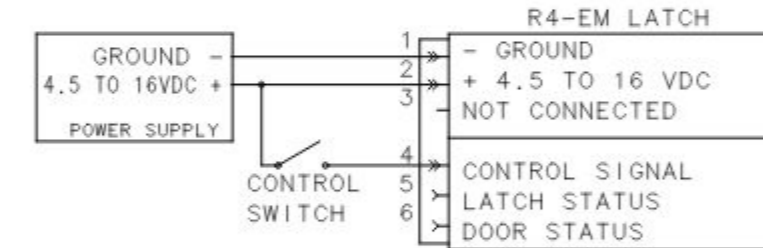

ELECTRICAL HOOKUP (OUTPUT/FEEDBACK)

CONNECTOR PINOUT	
PIN	FUNCTION
1	GROUND (-)
2	POWER (+)
3	NOT CONNECTED
4	CONTROL SIGNAL
5	LATCH STATUS
6	DOOR STATUS

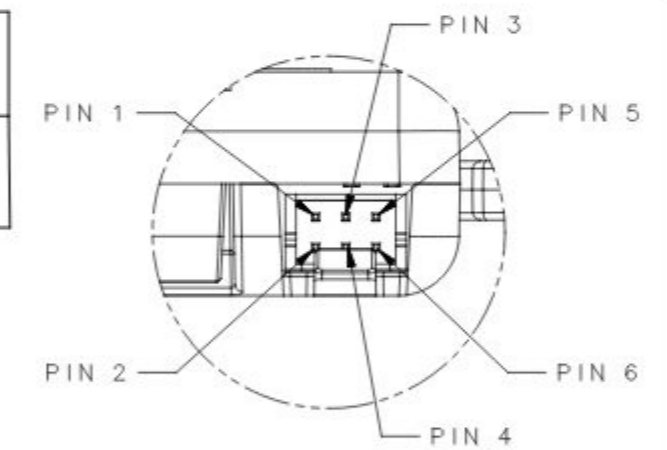

DETAIL A
SCALE 2:1

CONNECTOR PINOUT	FUNCTION	STANDARD OUTPUT		REVERSE OUTPUT	
		INACTIVE	ACTIVE (GROUND)	INACTIVE	ACTIVE (GROUND)
5	LATCH STATUS	LOCKED	UNLOCKED	UNLOCKED	LOCKED
6	DOOR STATUS	DOOR CLOSED	DOOR OPEN	DOOR OPEN	DOOR CLOSED

THIRD ANGLE PROJECTION			
MILLIMETERS [IN]			
TOLERANCES UNLESS OTHERWISE NOTED		DESCRIPTION	
SURFACE AREA N/A		ELECTRONIC ACCESS SOLUTION	
VOLUME N/A		MINIATURE ROTARY LATCH	
PROPRIETARY ITEM		SIZE A3	SYSTEM NX
EXCEPT FOR USES EXPRESSLY GRANTED IN WRITING, INFORMATION DISCLOSED HEREON IS CONFIDENTIAL AND ALL RIGHTS, PATENT AND OTHERWISE, ARE RESERVED BY SOUTHCO, INC.		DWG NO. J-R4-EM-05-1	
PER ASME Y14.5M-1994		DRAWN BY IGS/NPS	DATE 03JUL2019
		SCALE 1:1	SHEET 2 OF 2

REVISION HISTORY			
REV	DATE	BY	DESCRIPTION
B	07SEP2022	IGS/SKB	PRN: P2022-1127

SOUTHCO PERFORMANCE GUIDELINES

THE PERFORMANCE GUIDELINES SHOWN ON THIS PAGE ARE SUPPLIED AS A GENERAL GUIDE ONLY, AS CONDITIONS VARY WITH EACH APPLICATION AND METHOD OF INSTALLATION. STRENGTH DATA GIVEN IS FOR FAILURE OF THE PRODUCT OR FOR SUFFICIENT DEFORMATION TO MAKE THE PRODUCT INOPERABLE. NO SAFETY FACTOR HAS BEEN APPLIED. IT'S RECOMMENDED THAT THE USER REQUEST A PRODUCT SAMPLE FOR TESTING TO DETERMINE THE SUITABILITY OF THE PRODUCT FOR THE PURPOSE INTENDED AND THE USER'S PARTICULAR APPLICATION.

PERFORMANCE VALUES FOR R4-EM-05D20-150 SEE J-R4-EM-05-1.

- TESTING PERFORMED ON R4-EM-05D20-150.
- TENSILE FORCES (DIRECTION 1) ARE APPLIED AT THE NOMINAL LATERAL POSITION (ZERO MISALIGNMENT).
- MAXIMUM TENSILE FORCE (DIRECTION 1) ON THE CAM THAT THE LATCH CAN RELEASE (OPEN) ELECTRICALLY ONE TIME:
195 N (44 lbf)
- AVERAGE ULTIMATE TENSILE FORCE (DIRECTION 1) ON THE CAM BEFORE LATCH FAILURE: 4720 N (1061 lbf). THE LATCH DOES NOT RELEASE BUT DEFORMATION MAY OCCUR AFFECTING FUNCTIONALITY.
- AVERAGE TENSILE FORCE (DIRECTION 2) REQUIRED ON THE MECHANICAL OVERRIDE TRIGGER TO OPERATE (OPEN) THE LATCH MANUALLY WITH A TENSILE FORCE ON THE CAM:

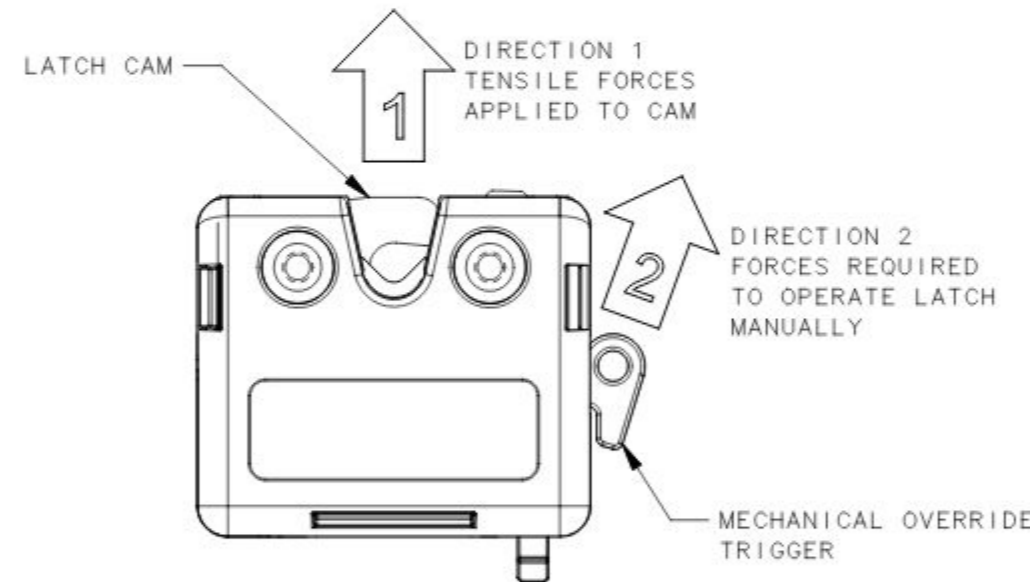

AVERAGE FORCE TO OPERATE LATCH WITH MECHANICAL OVERRIDE VS. LATCH CAM LOAD					
FORCE 1 (N) ON CAM	100 N (22.48 lbf)	200 N (44.96 lbf)	300 N (67.44 lbf)	400 N (89.92 lbf)	500 N (112.40 lbf)
FORCE 2 (N) ON MECHANICAL OVERRIDE	13.5 N (3.04 lbf)	22.5 N (5.06 lbf)	30.9 N (6.95 lbf)	38.9 N (8.75 lbf)	48.3 N (10.86 lbf)

- AVERAGE CLOSING FORCE 1 ON CAM 8.3 N (1.9 lbf) BASED ON ONE CYCLE.
- CYCLE LIFE WITH 20 N (4.5 lbf) TENSILE FORCE (DIRECTION 1) FOR R4-EM-05D20-150
TOTAL NUMBER OF CYCLES 50000 WITH TEST PROFILE AS FOLLOWS:
CHAMBER TEMPERATURE 0°C: 5000
CHAMBER TEMPERATURE 60°C: 5000
AMBIENT TEMPERATURE: 40000

REFERENCE FOR SOUTHCO INTERNAL USE ONLY:

- trR4-49439 ITEM 3
- trR4-49440 ITEM 4
- trR4-49437 ITEM 5
- trR4-49438 ITEM 6
- trR4-49275 ITEM 7

	THIRD ANGLE PROJECTION			
	MILLIMETERS [IN]			
SURFACE AREA	N/A	DESCRIPTION R4-EM-05-1 ELECTRONIC ACCESS SOLUTION		
VOLUME	N/A			
PROPRIETARY ITEM <small>EXCEPT FOR USES EXPRESSLY GRANTED IN WRITING, INFORMATION DISCLOSED HEREON IS CONFIDENTIAL AND ALL RIGHTS, PATENT AND OTHERWISE, ARE RESERVED BY SOUTHCO, INC.</small>		SIZE A3	SYSTEM NX	DWG NO. TD-R4-EM-05-1-J
PER ASME Y14.5M-1994		DRAWN BY IGS	DATE 20MAY2021	SCALE 1:1
		SHEET		1 OF 1